

RHINOCEROS

RH1200

MINI SKID STEER

DIMENSIONS(STD)

Operating weight	1855kg/4089.6lb
Rated capacity	462kg/1018.5lb
A Operating height, max std.bucket	2980mm
B Hinge pin height,max	2210mm
C Overall machine height	1420mm
D Overall length of machine, std. bucket	2980mm
E Overall length of machine,no attachment	2120mm
F Wheelbase	1180mm
G Unloading height, Max	1750mm
H Unloading distance	630mm
I Minimum ground clearance	145mm
J Departure angle	33°
K Approaching angle	25°
O Track peripheral width	560mm
M Unloading angle	25°
S Maximum horizontal pushing depth	90mm
P Width	932mm
Q Maximum width of track	920mm
R Track width	180mm

POWER

Model No.	KUBOTA D1703BM-DI-EF04
Fuel	Diesel
Rated power	18.2kw
Emissions compliance	EPATier 4/EU Stage V
Number of cylinders	3
Displacement	1.647L
Bore	88mm
Stroke	92.4mm
Rated speed	2200rpm

OPERATION

Ground drive speed	
Forward/reverse	6.5km/h
Ground pressure (ISO/CD 16754)	
(180-mm) Tracks	0.33bar
Gradeability	35%

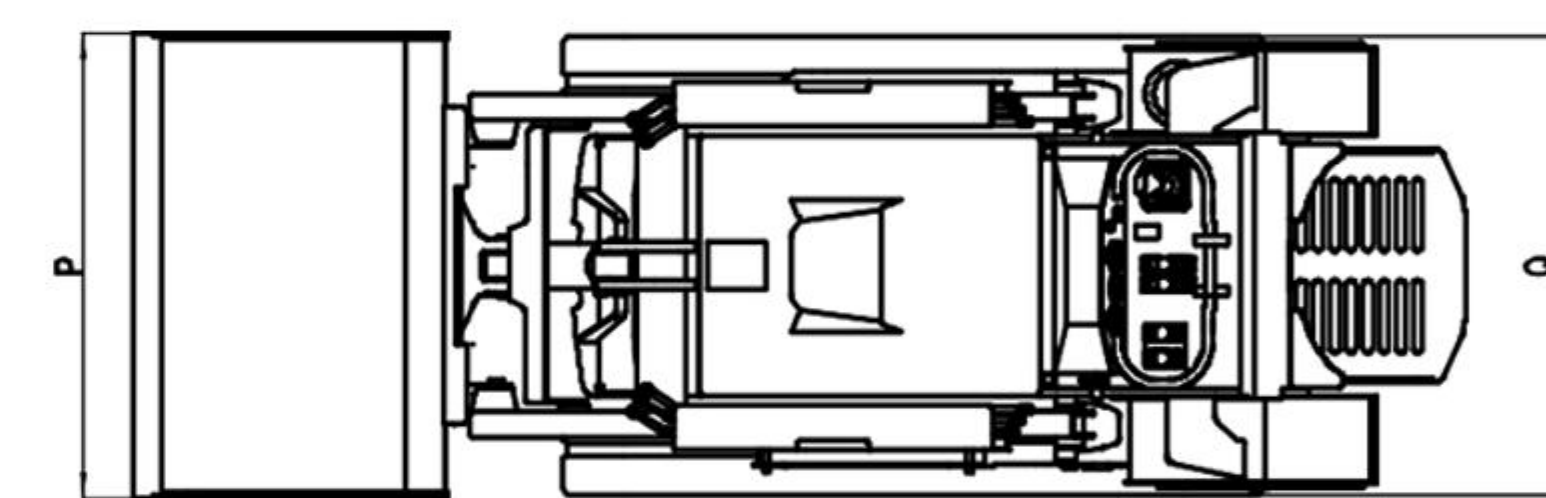
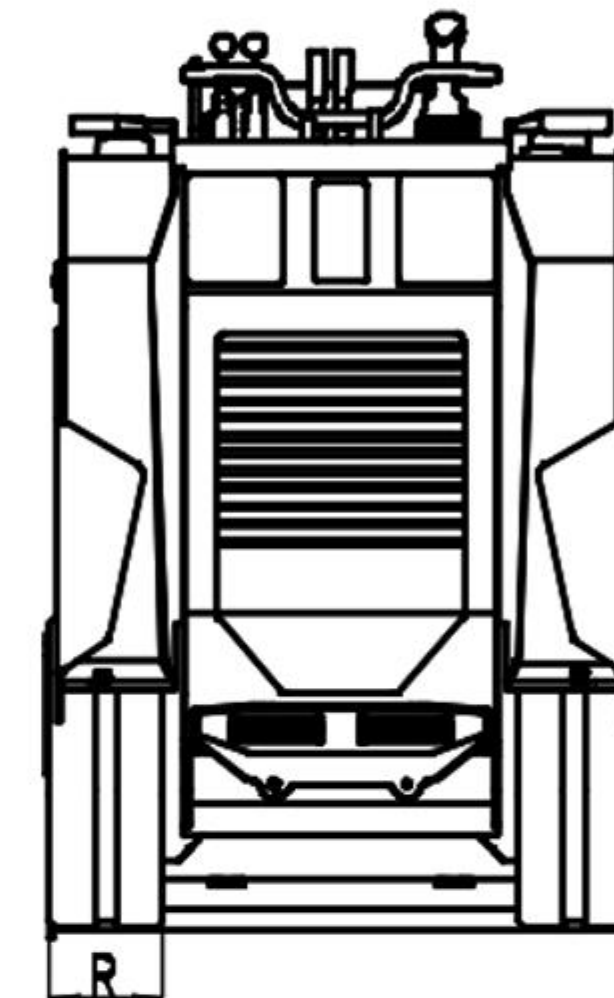
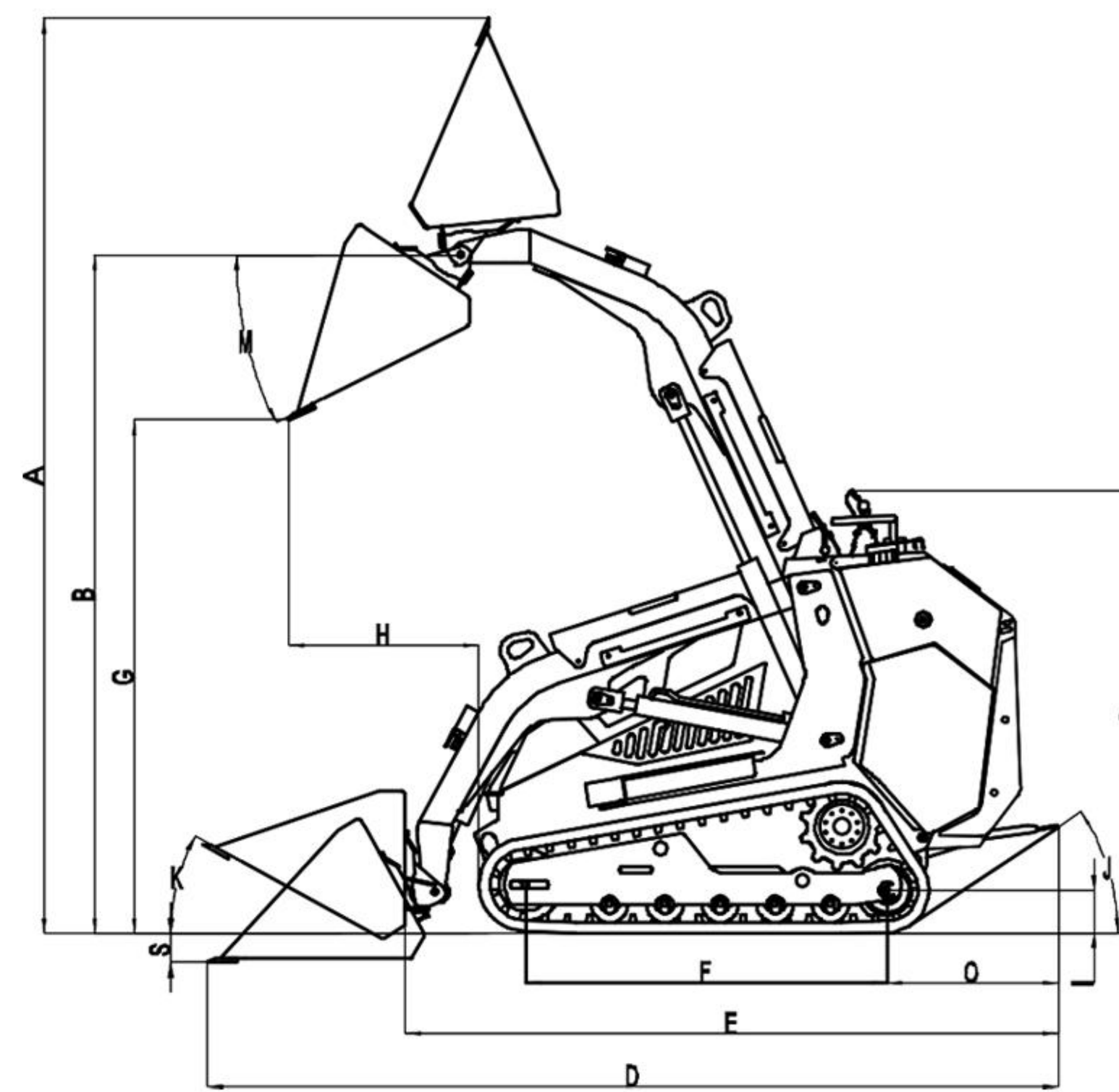

HYDRAULIC SYSTEM

Auxiliary circuit	
Ram pump	
Flow rate	89L/min
Pressure	200bar

FLUID CAPACITIES

Fuel tank capacity	10.5gal
Lubricating oil capacity	1.3gal
Hydraulic reservoir capacity	9.5gal



- VALVE:TAIFENG
- MAIN PUMP:ITALIAN BONDOLI PUMP
- AUXILIARY PUMP:WANYE PUMP
- TRAVELING MOTOR:HENGLI



RH1200

MINI SKID STEER