

KS3000

BUGGY

DIMENSIONS (STD)		U.S.(in)	METRIC(mm)
a	Wheelbase	57.09	1450
b	Length	113.78	2890
c	Steering wheel height	94.96	1650
d	Height	97.24	2470
e	Width	42.91	1090
f	Tire width	8.27	210
g	Ground clearance	5.31	135
h	Unloaded back end height from ground	72.83	1850
i	Unloaded front end height from ground	14.17	360
j	Left rotation angle	30°	
k	Right rotation angle	30°	
m	Tipping bucket left rotation angle	90°	
n	Tipping bucket right rotation angle	85°	
L+J Max. Tipping bucket left rotation angle		120°	
K+M Max. Tipping bucket left rotation angle		120°	

POWER			
Engine	Kubota D1105		
Fuel	Diesel		
Gross power rating	19 hp	14.2kW	
Emissions compliance	EPA Tier 4	EU Stage V	
Number of cylinders	3		
Displacement	68.53in ³	1.123 L	
Bore	3.07 in	78 mm	
Stroke	3.09 in	78.4mm	
Rated speed	2,200rpm		

OPERATION			
Max traveling speed	4.97 mph	8km/h	
Forward/reverse	4.97 mph	8km/h	
Ground clearance	5.31in	135mm	
Tire model	23*8.5-12	23*8.5-12	

HYDRAULIC SYSTEM			
Pump type	Plunger variable pump		
Working pressure	3,190 psi	220 bar	
Max. flow	99L/min	99L/min	

FLUID CAPACITIES			
Hydraulic oil tank capacity	10.5gal	40L	
Diesel oil tank capacity	10.3gal	39L	

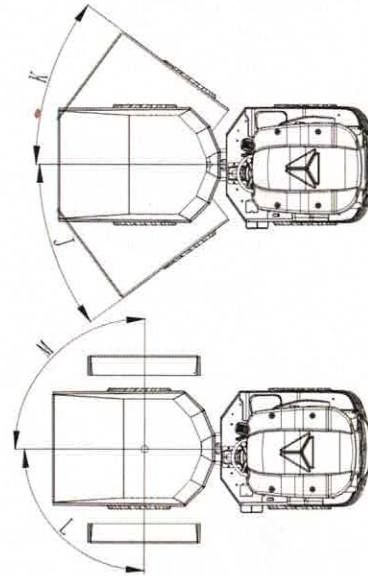
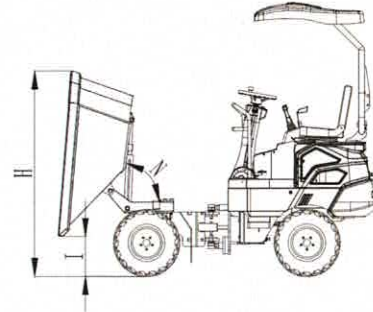
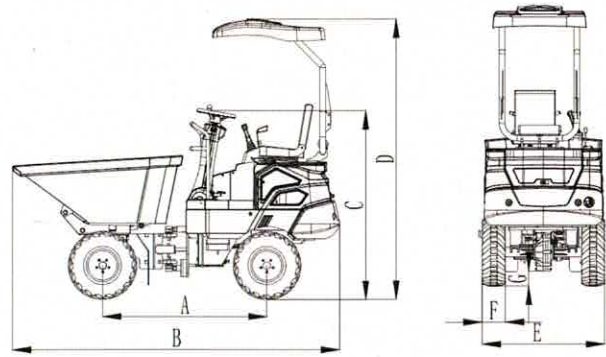

BATTERY			
Operation weight	3480lb	1580kg	
Maximum load weight	3000lb	1360kg	
Tipping bucket capacity	17.6in ³	0.5m ³	
Working type	Rotary selfdump		

www.rhinocerosequipment.com



SHANDONG KEN STONE HEAVY MACHINERY CO.,LTD



Address : Dingyuanzhai Industrial Park, Guan County, Liaocheng city, Shandong Province, China
 Postal code : 252512
 Website : www.rhinocerosequipment.com
 E-mail : office@sdxinu.com