

RHINOCEROS

RH80E

CRAWLER EXCAVATOR

MAIN DIMENSIONS

A	Wheel tread	2200mm
B	Track length	2750mm
C	Platform ground clearance	720mm
D	Platform tail end turning radius	1580mm
E	Chassis width	2150mm
F	Track width	400mm
G	Chassis ground clearance	345mm
H	Track height	650mm
I	Traveling length	6055mm
J	Cab ceiling height	2460mm
K	Traveling width	2015mm

SPECIFICATION

Operating weight	7200kg	
Working device	3.5m boom + 1.75m arm	
Standard bucket capacity	0.3 cbm	
Engine	Model No.	Yanmar 4TNV98-ZCSLKC
	Displacement	3.319L
	Rated power/speed	46.3KW/2200rpm
	Max. torque	223.3-243.5N.m/1600±100rpm
Speed	Max.travel speed	4/2 km/h
	Swing speed	9 rpm
	Max.grade ability	35°
Hydraulic and liquid capacity	Hydraulic system	Load sensing system
	Pump type	Variable pump
	Pressure	39kPa
	Hydraulic oil tank capacity	118L
	Fuel tank capacity	170L
	Engine fuel tank capacity	12L

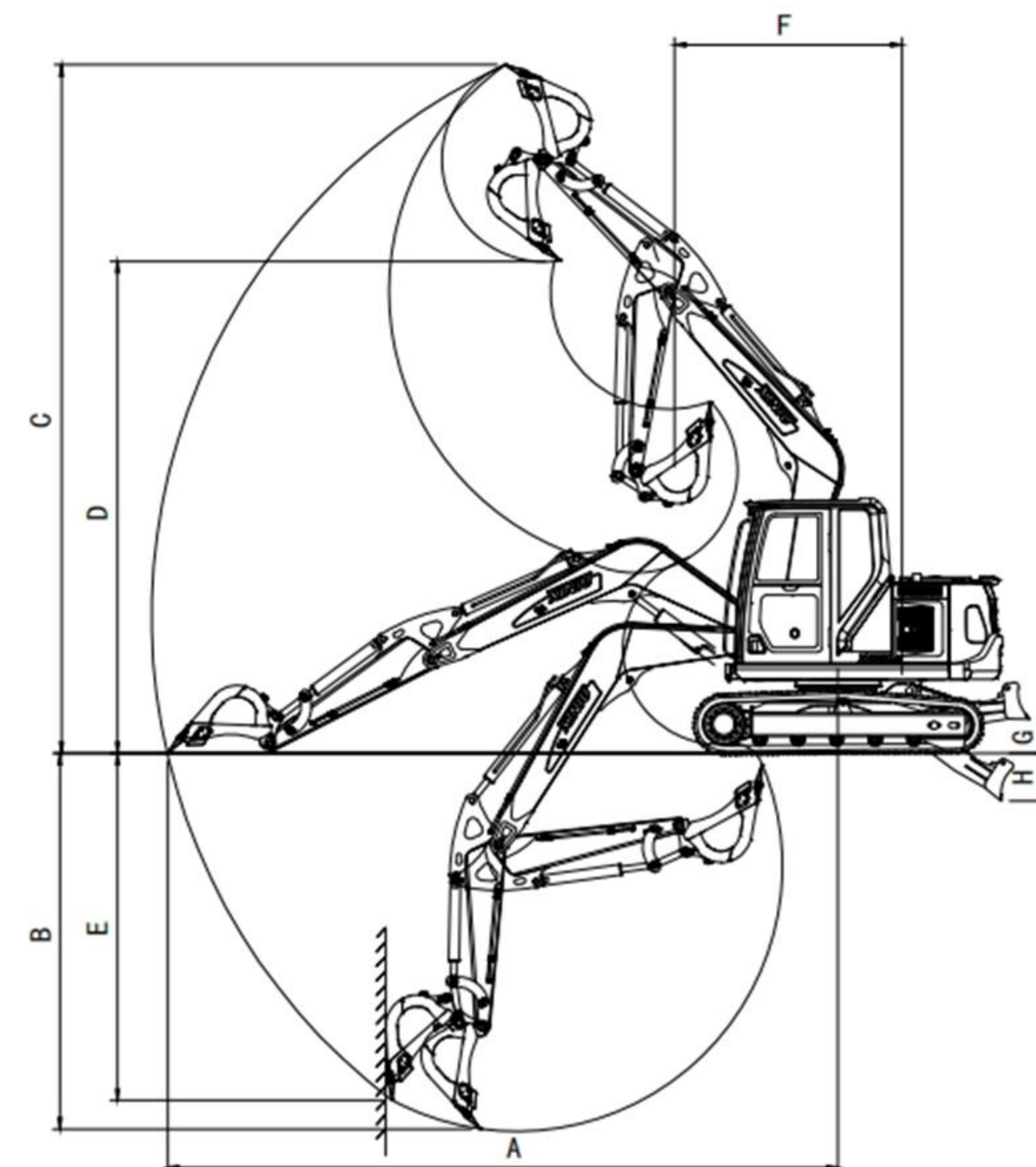
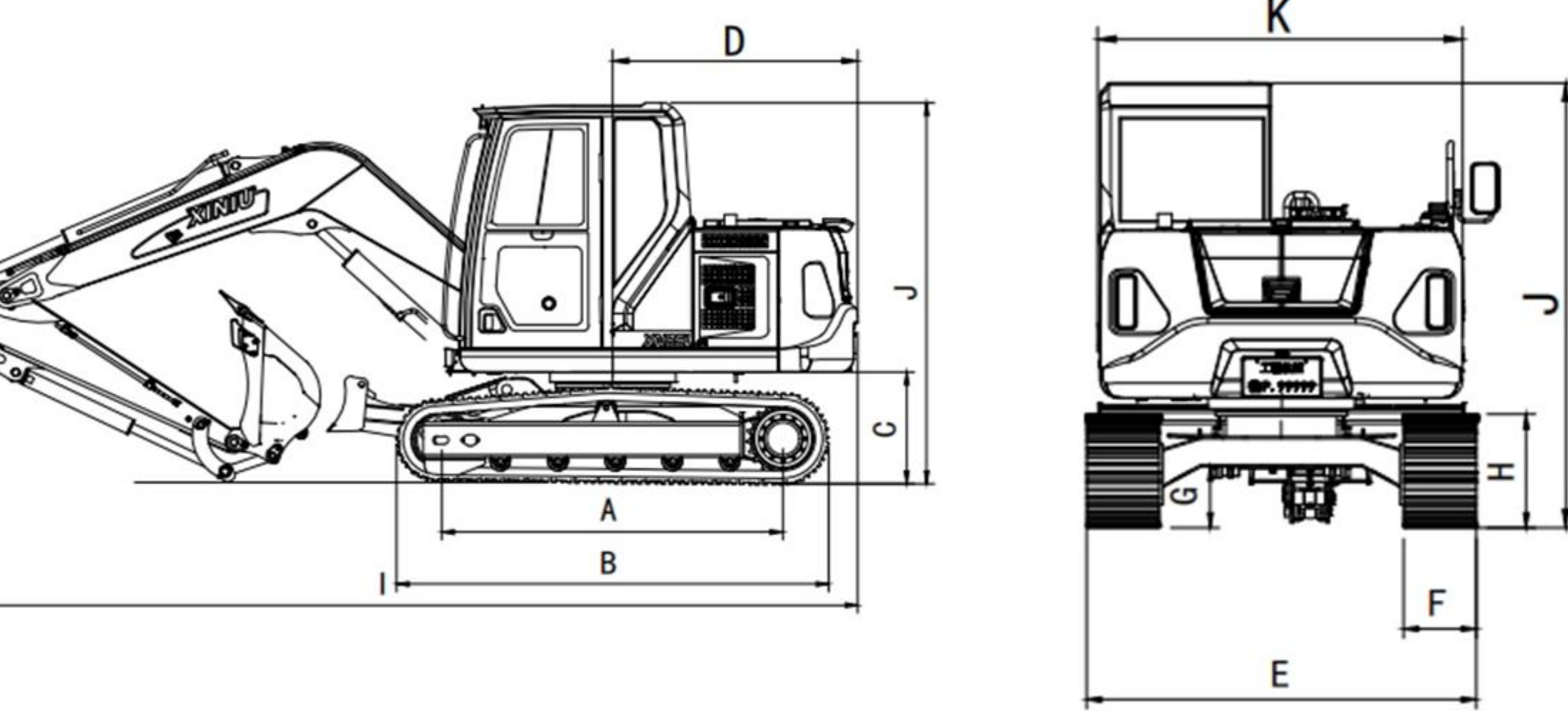

OPERATING RANGE

A	Max. ground digging radius	6435mm
B	Max. digging depth	3600mm
C	Max. digging height	6615mm
D	Max. dump height	4725mm
E	Max.vertical digging depth	3330mm
F	Min. swing radius	2180mm
G	Max.lifting height of bulldozer	370mm
H	Max.excavation depth of bulldozer	440mm
	Bucket digging force	52KN
	Bucket arm digging force	38KN



- VALVE:REXROTH
- MAIN PUMP: REXROTH
- TRAVELING MOTOR:HENGLI
- SWING MOTOR:ZHONGRUN



RH80E

CRAWLER EXCAVATOR