

# KS908E

## MINI LOADER

### SPECIFICATION

Operating weight	2560kg	
Operating capacity	0.30m <sup>3</sup>	
Max.tractive force	19 KN	
Max.rising power	800	
Driving forward speed	12km/h	
Ground clearance	220mm	
Tire mode	31*15.50-15-15	
Power	Walking motor model	TZ210XQ8H-80KS/ TZ210XQ8H-80KS-Z
	Rated power	8kw/8kw
	Max.torque	129Nm/129Nm
Hydraulic system	Oil pump motor model	TZ170XS75-M26
	Rated power	7.5kw
	Max.torque	110Nm
	Pump type	Gear pump
	Flow rate	60L/min
Capacity	Pressure	21Mpa
	Battery capacity	16.56kwh
	Working voltage	72 V
	Hydraulic oil	40 L

### OPERATING RANGE

A	Total length with standard bucket	3808mm
B	Axle spacing	1522mm
C	Overall height	2660mm
D	Seat height	1496mm
E	Departure angle	37°
F	Approach angle	47.5°
G	Overall width	1560mm
H	Work distance	200mm
I	Max.unloading angle	48°
J	Dumping height	1934mm
K	Level load height	2430mm
L	Bucket hinge point height	2670mm
M	Overall working height	3222mm
N	Max. horizontal pushing depth	44mm
O	Axis to bucket pin	639mm
P	Turning angle	46°

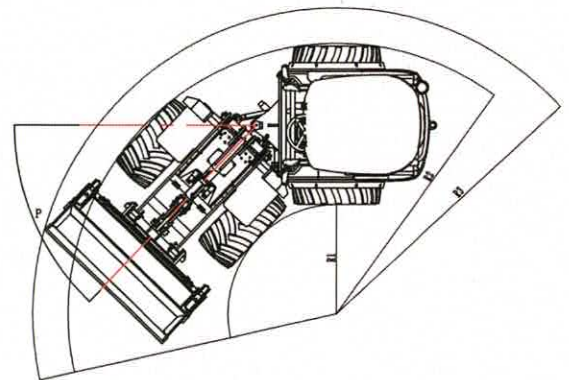
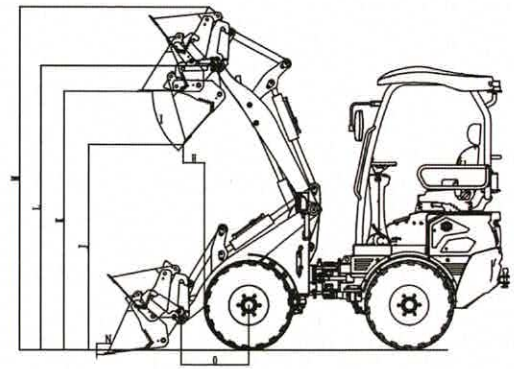
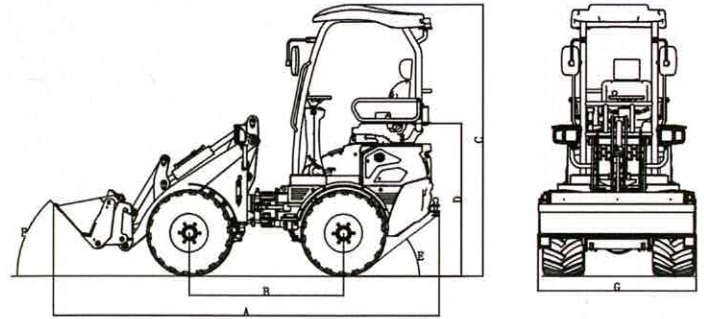

R1	Inner turning radius	1025mm
R2	Turning radius	2537mm
R3	Horizontal passing radius	2872mm

[www.rhinocerosequipment.com](http://www.rhinocerosequipment.com)



SHANDONG KEN STONE HEAVY MACHINERY CO.,LTD



Address : Dingyuanzhai Industrial Park,Guan County,Liaocheng city, Shandong Province, China  
 Postal code : 252512  
 Website : [www.rhinocerosequipment.com](http://www.rhinocerosequipment.com)  
 E-mail : [office@sdxiniu.com](mailto:office@sdxiniu.com)