

RHINOCEROS

RH925

MINI SKID STEER

DIMENSIONS (STD)	U.S.	METRIC
Machine weight (no attachment, fluids full)	3306.9lb	1500kg
Operating capacity		
35% tipping capacity	1000lb	454kg
Tipping capacity	2861.6lb	1298kg
A Operating height,max std.bucket	117in	2980mm
B Hinge pin height,max	86.5in	2210mm
C Overall machine height	56in	1420mm
D Overall length of machine,std.bucket	117in	2980mm
E Overall length of loader,no attachment	83.5in	2120mm
F Wheelbase/track length	46.5in	1180mm
G Unloading height	69in	1750mm
H Unloading distance	25in	630mm
I Ground clearance,min	5.7in	145mm
J Angle of departure	33°	
K Angle of approach	25°	
L Track outer width	22in	560mm
M Angle of unloading	25°	
N Max. horizontal pushing depth	3.5in	90mm
O Overall width	36.7in	932mm
P Track width,max	36.2in	920mm
Q Track's width	7in	180mm
POWER	U.S.	METRIC
Model No.	Kubota D902	
Fuel	Diesel	
Gross power rating	15.82hp	11.8kw
Emissions compliance	EPA Tier 4	EU Stage V
Number of cylinders	3	
Displacement	63.89in³	1.047L
Bore	2.83in	72mm
Stroke	2.9in	73.6mm
Rated speed	2300rpm	

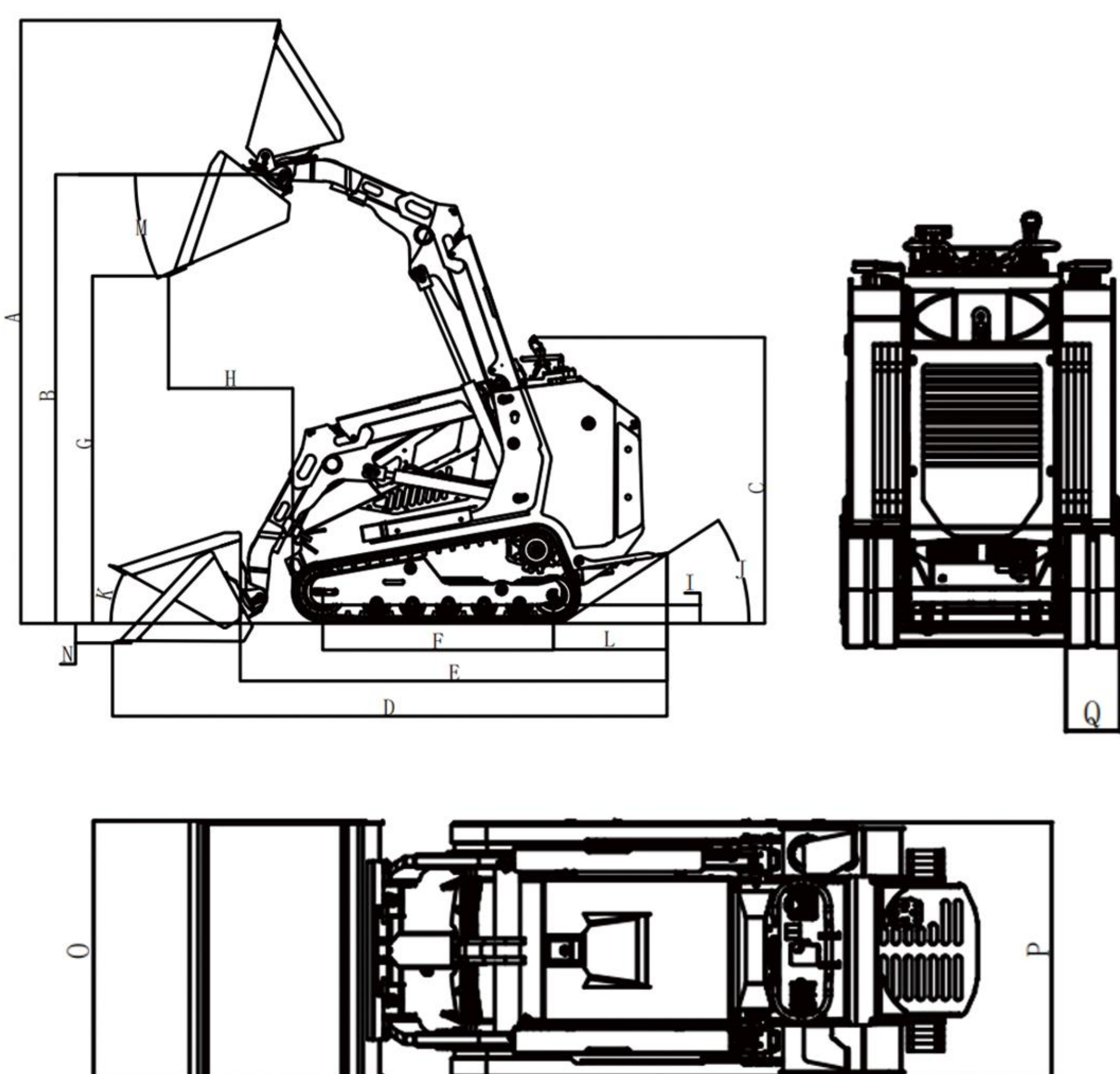

OPERATION	U.S.	METRIC
Ground drive speed		
Forward/Reverse	3.1mph	5km/h
Ground pressure(ISO/CD 16754)		
7-In(180-mm)tracks	4.78psi	0.33bar

HYDRAULIC SYSTEM I	U.S.	METRIC
Auxiliary circuit		
Piston pump		
Flow rate	404.gpm	89L/min
Pressure	2900.75psi	200bar

FLUID CAPACITIES	U.S.	METRIC
Fuel tank capacity		42L
Lubricating oil capacity		4L
Hydraulic reservoir capacity		40L

BATTERY	U.S.	METRIC
SAE reserve capacity rating		110min
SAE cold crank@ 0° F (-18°C)		800amps
Electrical system		12V



- VALVE:JINGKEN
- MAINPUMP:JINGKEN
- TRAVELING MOTOR:HENGLI



RH925

MINI SKID STEER